

Monoblocchi frigoriferi per Armadi

Vantaggi Economici

- riduzione costi di installazione.
- riduzione costi di gestione.
- riduzione costi post-vendita.

Vantaggi Costruttivi

- rapida installazione.
- cablaggi elettrici immediati.
- evaporatore integrato nell'unità, vano frigorifero libero da ingombri
- evaporazione autonoma dell'acqua di condensa.
- dimensioni unificate delle unità, evitano la diversificazione di produzione di armadi e banchi.

Tecnologia Innovativa

- struttura realizzata con materiali d'avanguardia per uso alimentare.
- rendimenti frigoriferi elevati.
- gas refrigeranti ecologici.
- ventilazione forzata.
- classe climatica 5 (in accordo con UNI EN ISO 23953-2).
- brevettato.
- *disponibile in versione ad alta efficienza grazie all'impiego di motoventilatori e compressori a basso consumo.*



Cooling Plug-in units for cabinets

Economic Advantages

- reduced installation costs.
- reduced running costs.
- reduced after-sales costs.

Construction Advantages

- fast installation.
- immediate electrical wiring.
- evaporator built into the unit so that no space in the refrigerating compartment is taken up.
- autonomous evaporation of condensation.
- units are of unified sizes, which avoids diversifying production of cabinets and refrigerator counters.

Innovative Technology

- structure made using food-safe cutting-edge materials .
- high refrigerating performance.
- ecological refrigerating gases.
- forced ventilation.
- climatic class 5 (in conformity with UNI EN ISO 23953-2).
- patented.
- *available in a high efficiency version, thanks to the use of motorised fans and low-consumption compressors.*



Monoblocs frigorifiques pour Armoires

Avantages Economiques

- réduction des coûts d'installation.
- réduction des coûts de gestion.
- réduction des coûts après-vente.

Avantages Structuraux

- installation rapide.
- câblages électriques immédiats.
- évaporateur intégré à l'unité, compartiment frigorifique sans encombrements.
- évaporation autonome de l'eau de condensation.
- dimensions unifiées des unités, évitant la diversification de production d'armoires et de comptoirs.

Technologie Innovante

- structure réalisée avec des matériaux d'avant-garde à usage alimentaire.
- hauts rendements frigorifiques.
- gaz réfrigérants écologiques.
- ventilation forcée.
- classe climatique 5 (conformément à la norme UNI EN ISO 23953-2).
- breveté.
- *disponible dans la version à haute efficacité grâce à l'utilisation de motoventilateurs et de compresseurs à faible consommation.*



Monobloques frigoríficos para Armarios

Ventajas Económicas

- reducción de los costos de instalación.
- reducción de los costos de gestión.
- reducción de los costos post-venta.

Ventajas Constructivas

- rápida instalación.
- cableados eléctricos inmediatos.
- evaporador integrado en la unidad, vano frigorífico libre de ocupaciones.
- evaporación autónoma del agua de condensación.
- dimensiones unificadas de la unidad para evitar la diversificación de producción de armarios y bancos.

Tecnología Innovadora

- estructura realizada con materiales de vanguardia para uso alimentario.
- rendimientos frigoríficos elevados.
- gases refrigerantes ecológicos.
- ventilación forzada.
- clase climática 5 (según UNI EN ISO 23953-2).
- patentado.
- *disponible en una versión de alta eficiencia, gracias al empleo de motoventiladores y compresores de bajo consumo.*

Working Condition ST52 TH / THR

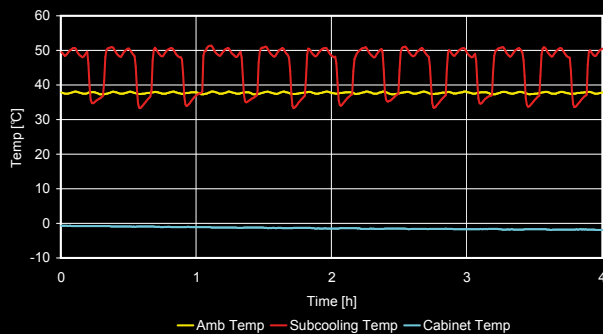

Kühlblöcke für Kühlschränke

Wirtschaftliche Vorteile

- Reduzierte Installationskosten.
- Reduzierte Betriebskosten.
- Reduzierte After-Sales-Kosten.

Konstruktionsvorteile

- Schnelle Installation.
- Einfache elektrische Anschlüsse.
- Verdampfer in die Kühleinheit integriert, komplett freier Kühlbereich.
- Automatische Kondenswasserverdunstung.
- Dank der standardisierten Maße der Kühleinheiten geringere Diversifikation bei der Produktion von Kühlschränken und -theben.

Innovative Technologie

- Struktur aus fortschrittlichen, lebensmittelverträglichen Materialien.
- Hohe Kühlleistung.
- Umweltfreundliche Kühlgase.
- Zwangslüftung.
- Klimaklasse 5 (in Übereinstimmung mit UNI EN ISO 23953-2).
- Patentiert.
- *Es ist auch in effizienten Ausführung erhältlich, bei der Motorlüfter und Kompressoren mit niedrigem Energieverbrauch eingesetzt werden.*

Installazione - Installation

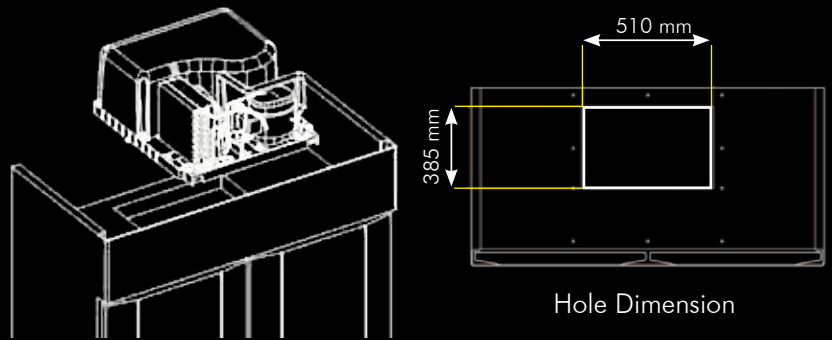

Dimensioni - Dimensions



	Alimentazione Supply	Potenza Frigorifera Comp. Comp. Cooling Capacity	Potenza Elettrica Power Consumption	Gas Ecologico Ecological Gas	Volume Refrigerato Refrigerated Volume	Temperatura d'impiego Operating Temperature	Peso Weight
ST52 TH	230V - 50Hz	550 W*	470 W*	R134a	1400 lt	0°/+10°C	19 Kg
ST52 THR	230V - 50Hz	550 W*	470 W*	R134a	1400 lt	-2°/+10°C	19 Kg

Tutti i dati sono indicativi e possono essere variati senza preavviso da TECO. All data are approximate and may be changed without notice by TECO.

* Ashrae: amb. - room +35°C / evap. -8°C / cond. +55°C.

